

DPF73003 TRIPLE-AXIS BILEVEL STEP MOTOR DRIVER PACK

- Three-Axis Package
- Integrated 500 Watt Power Supply
- 10 Amperes/Phase Maximum Operating Current
- 7 Amperes/Phase Standstill Motor Current
- Bilevel Drive Operation
- Half-Step and Full-Step Operation
- No RFI or EMI Problems
- TTL/CMOS Compatible Inputs
- Clock and Direction or Dual Clock Operation
- Motor On-Off Input
- Short and Open Circuit Protection
- Fault Out output and Fault LED

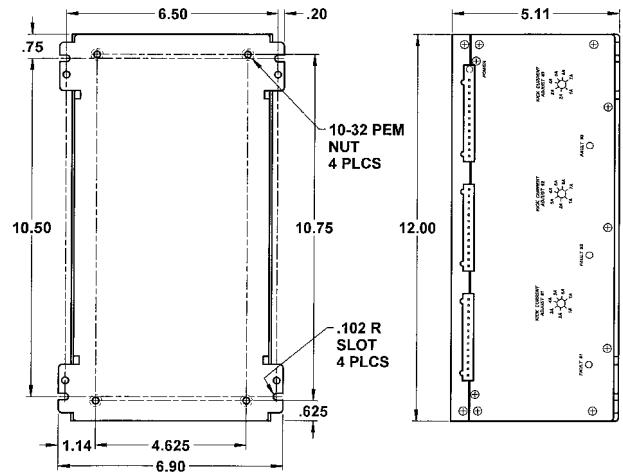

FIGURE 1: DIMENSION DRAWING

GENERAL DESCRIPTION

The DPF73003 Step Motor Driver Pack is designed to operate three axes of 4-phase step motors rated at 1 - 7 amps/phase. These Driver Packs contain a three-axis step motor driver, a 500 Watt power supply, and a cooling fan. Outstanding motor performance is provided by means of a bilevel drive technique.

BILEVEL DRIVE

The basic function of a step motor driver is to control the motor winding currents. Motor performance is determined by how fast the driver can increase and decrease the winding currents. A rapid rise in winding current is achieved by applying a high voltage directly to a motor. This rapid rise of current is also referred to as the "kick" or operating current. When a desired current level is reached, a low voltage is applied to maintain a suitable holding current level. When a motor winding is turned off, a rapid decrease in winding current is achieved by routing the energy in the collapsing field back to the power supply through a high voltage path. The high voltage supply furnishes the energy necessary to maintain motor output torque at high step rates thus providing high mechanical power output. The low voltage supply provides much of the current needed at low step rates and all of the holding current.

Bilevel drivers do not use high frequency switching techniques as chopper drivers do. Consequently, they do not create the EMI, RFI, and motor heating problems that are associated with chopper drivers.

EXCITATION MODE SELECT

Users have a choice of dual-phase, full-step operation or half-step operation. Dual-phase, full-step operation occurs by energizing two phases at a time, rotating a typical motor 1.8 degrees per step. Half-step operation occurs by alternately energizing one, and then two, phases at a time, rotating the motor 0.9 degrees per step. Full-step operation is only suggested for applications that specifically require that mode, such as when retrofitting existing full-step systems.

STEP AND DIRECTION CONTROL

The DPF73003 has two clock options: Clock and Direction, or Dual Clock operation. Terminal 5 can be configured as the Direction Input or CCW Input by placing jumper JP2, JP8, and JP14 in the appropriate position (see Table 1). Pulses applied to the Clock input cause the motor to step in the clockwise direction if the Direction Input is a logic "1" or the counterclockwise direction if the Direction Input is a logic "0". Pulses applied to the CCW Input cause the motor to step in the counterclockwise direction. Either positive or negative going pulses may be selected by setting JP1, JP7, and JP13 to the appropriate position (See Table 1).

MOTOR ON/OFF INPUT

The motor on/off input allows for de-energizing a motor without disturbing the positioning logic. After re-energizing the motor, a routine can continue. This reduces motor heating and conserves power, especially in applications where motors are stopped for long periods and no holding torque is required.

ORDERING INFORMATION

DPF73003	3-AXIS DRIVER PACK
DPF73003X250A	DRIVER PACK WITH OPTIONAL 250VAC INPUT
BL73	REPLACEMENT BOARD FOR DRIVER PACK
BL73-1	STANDALONE DRIVER ONLY

ADJUSTING KICK CURRENT

The kick (or operating) current level is the desired phase current level that the high voltage provides each time a step is taken. The high voltage is turned off when this level is reached. The kick current level should be set to approximately 1.4 times the rated phase current. For example, a motor rated at 5 amps/phase should be "kicked" to 7 amps (5 x 1.4 = 7). Table 2 shows various kick current levels for corresponding phase currents.

WARNING: The kick current level must be set before operating a motor.

JUMPER SETTINGS:

FUNCTION	JP 1,7, &13	JP 2,8, &14
NEGATIVE GOING CLOCKS	1-2	X
POSITIVE GOING CLOCKS	2-3	X
TERMINAL 5 = CCW	X	1-2
TERMINAL 5 = DIRECTION	X	2-3
STANDARD PRODUCT	1 - 2	2 - 3

TABLE 1: JUMPER SETTINGS

SPECIFICATIONS

Control Inputs (All) : (Terminals 5, 6, 8, 9)

TTL-compatible
 Logic "0" - 0 to 0.8 V
 Logic "1" - 3.5 to 5.0 V

Clock Inputs : (Terminals 5 & 6)

15 microseconds minimum pulse width required. The Clock inputs are internally pulled down to 0Vdc through a 10KΩ resistor for positive going Clock inputs or pulled up to +5Vdc through a 10KΩ resistor for negative going Clock inputs.

Fault Reset: (Terminal 4)

Pulled up to +5Vdc through a 10kΩ resistor.
 Logic "1" (open) - Driver enabled
 Logic "0" - Resets a Fault condition (driver is disabled when this input is low). This input must be held low for at least 100ms.

Direction Control: (Terminal 5)

Logic "1" (open) - CW motor direction
 Logic "0" - CCW motor direction

Excitation Mode Select: (Terminal 8)

Logic "1"(open) - Half-step
 Logic "0" - Full-step

Motor On/Off: (Terminal 9)

Logic "1" (open) - motor current on
 Logic "0" - motor current off

Fault Output: (Terminal 10)

Open Drain Output
 Logic "0" (low) - Driver Fault Detected
 Logic "1" (open drain) - No Fault

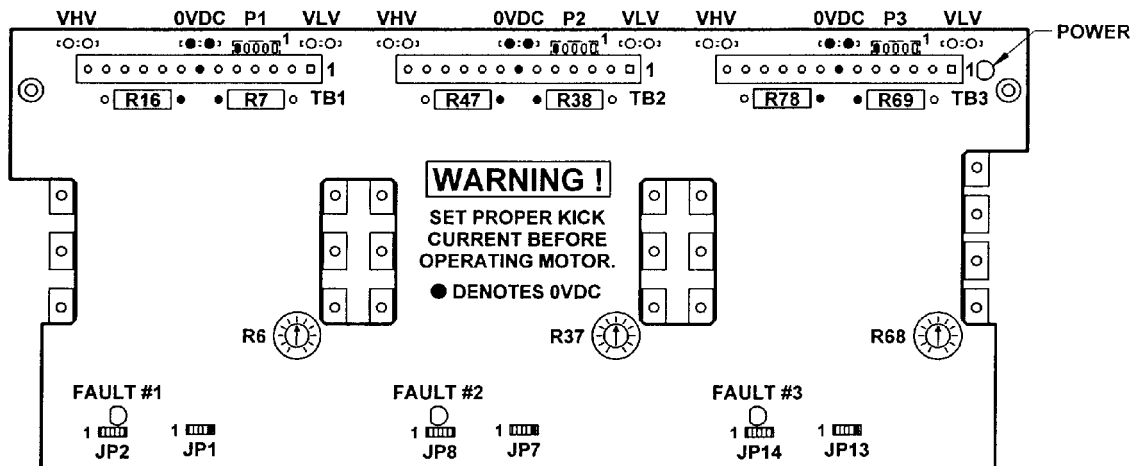

FIGURE 2: BL73 JUMPER LOCATIONS

Output Current Rating:

Terminals (1, 2, 3, 11, 12, & 13)

10 Amps per phase maximum operating or running current, and 7 Amps per phase maximum standstill current. Motor phase ratings of 1.0 Amp minimum are required to meet the minimum kick level.

Power Requirement :105 to 125VAC

Note: DPF73003 Driver Packs are available with 250VAC power input upon request. Order Part Number DPF73003X250.

Operating Temperature : 0 to 60 degrees C

The DPF73003 contains an internal fan to create airflow through the unit. Heating considerations should include: location where unit is mounted, the duty cycle of operation, ambient temperature and air flow. Care should be taken so that no point on the chassis exceeds 60 degrees Celsius.

Fuse Rating: Standard Unit - 5 Amp Fast Blow, 5x20mm
 Littlefuse part # 217005
 X250 Unit - 5 Amp Fast Blow, 3AG
 Littlefuse part # 312005

MOTOR CONNECTIONS

Figures 3 and 4 are hookup diagrams for typical DPF73003 driver applications. *Wiring connected to inputs must be separated from motor connections and all other possible sources of interference.*

IMPORTANT NOTE: When the wiring from the driver to the step motor extends beyond 50 feet, consult the factory.

13 PIN TERMINAL DESCRIPTION:

TERMINAL	DESCRIPTION
1	Motor, Phase 1
2	Motor, Phase 3
3	Motor, Common 1,3
4	Fault Reset
5	Direction (CCW)
6	Clock (CW)
7	0Vdc
8	Half-step/Full-step
9	On/Off
10	Fault Out
11	Motor, Common 2,4
12	Motor, Phase 2
13	Motor, Phase 4

TABLE 2: 13-PIN TERMINAL

HOOKUP DRAWING

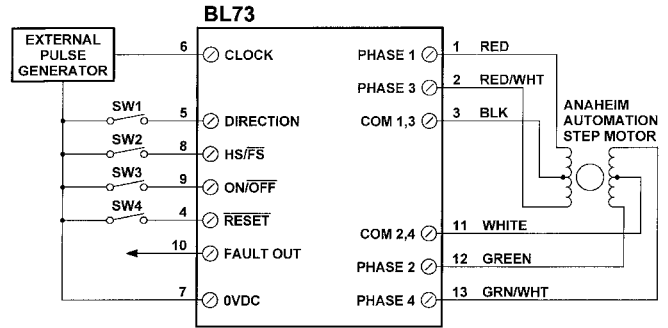

FIGURE 3: BL73 HOOKUP DRAWING

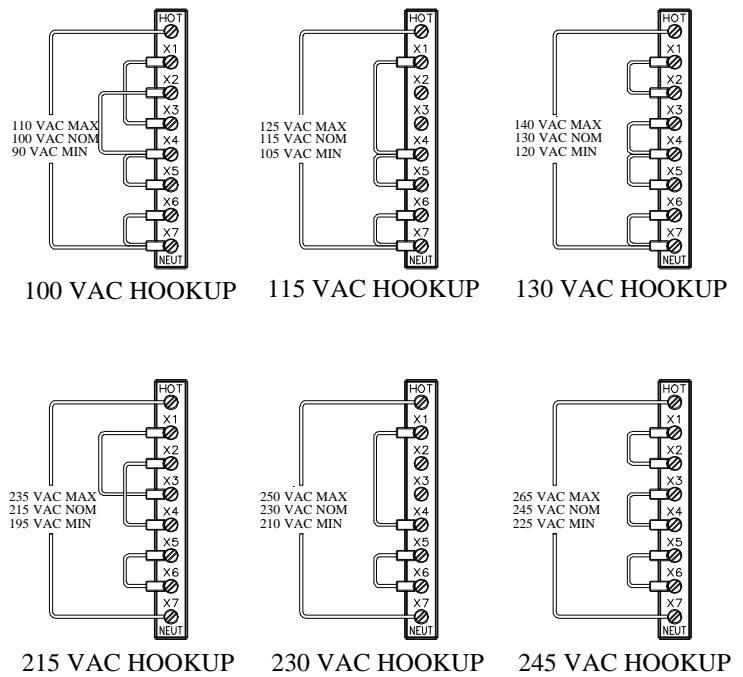

FIGURE 4: HOOKUP DIAGRAM FOR X250 VERSION

TORQUE/SPEED CURVES

